

IL SISTEMA SERIE 200 REGOLABILE permette, combinando l'uso dei carrelli superiori dritti e piegati, di poter utilizzare ante con spessore variabile tra 14 mm. e 30 mm. consentendo di soddisfare i piu' svariati utilizzi di costruttori e progettisti.

The ADJUSTABLE SYSTEM SERIES 200 makes it possible to use doors with varying thickness between 14 and 30 mm. by combining upper trucks with or without groove, and to meet the designer's and manufacturer's requirements.

Sezione verticale / Vertical section

KIT 0207 AC - MAX 15 KG

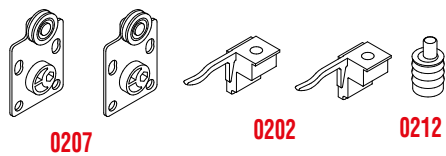

KIT 0208 AC - MAX 25 KG

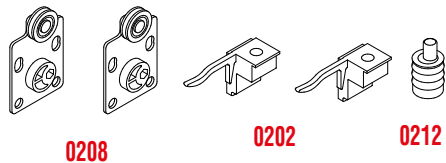

KIT 0209 AC - MAX 25 KG

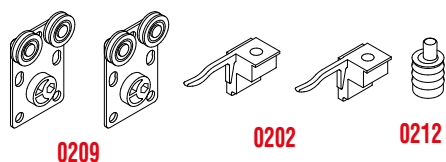

KIT 0210 AC - MAX 40 KG

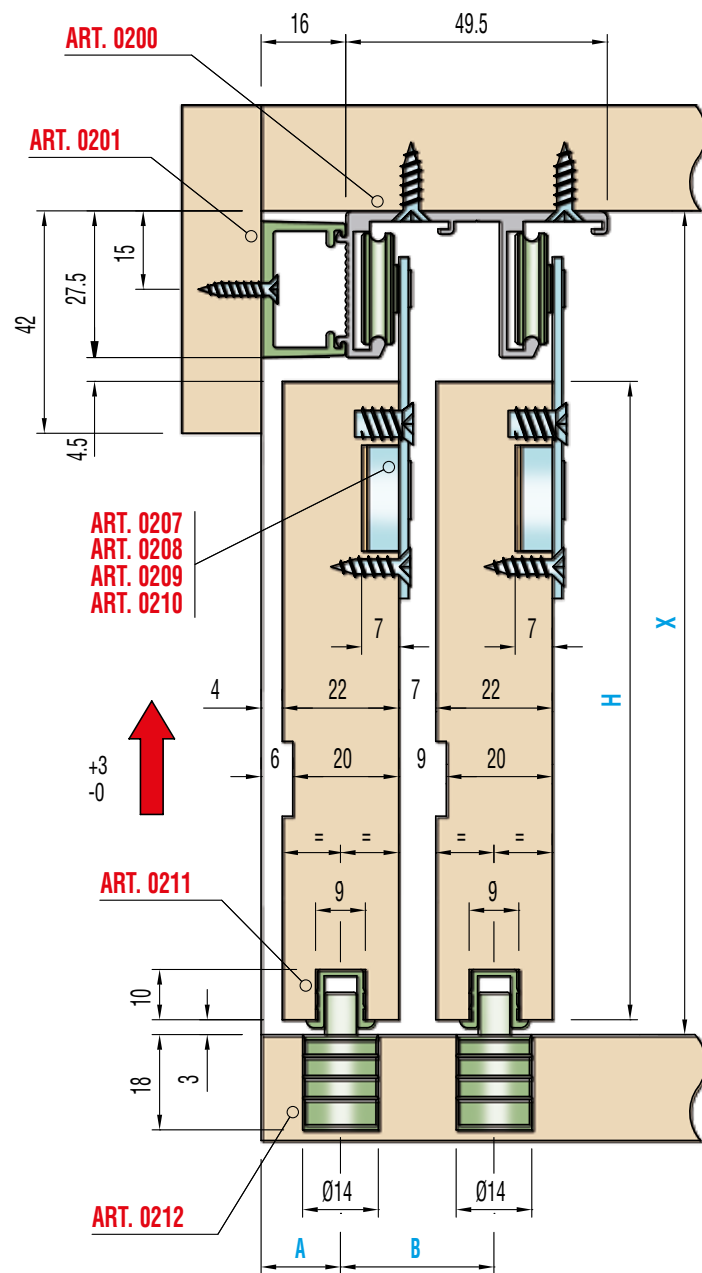
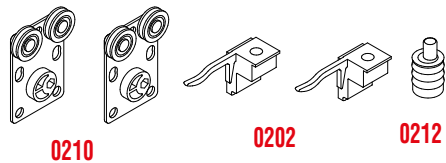

H =	X -35
A =	26 -S*/2
B =	29

S* (spessore / thickness)
min.20 - max 22

Legenda KIT / Kit Legend

0202	Fermo superiore dx - sx <i>Right hand - left hand upper stopper</i>
0207	Carrello con 1 rullo con eccentrico <i>Truck with 1 roller with eccentric</i>
0208	Carrello con 1 cuscinetto con eccentrico <i>Truck with 1 ball bearing with eccentric</i>
0209	Carrello con 2 rulli con eccentrico <i>Truck with 2 rollers with eccentric</i>
0210	Carrello con 2 cuscinetti con eccentrico <i>Truck with 2 ball bearings with eccentric</i>
0212	Guida inferiore eccentrica <i>Lower eccentric runner</i>

Legenda altri componenti Legend other items

0200		Profilo alluminio superiore <i>Upper aluminium profile</i>
0211		Profilo plastica inferiore <i>Lower plastic profile</i>
0201		Supporto per copertura <i>Clip for cover</i>

Schema Foratura ante / Doors drilling

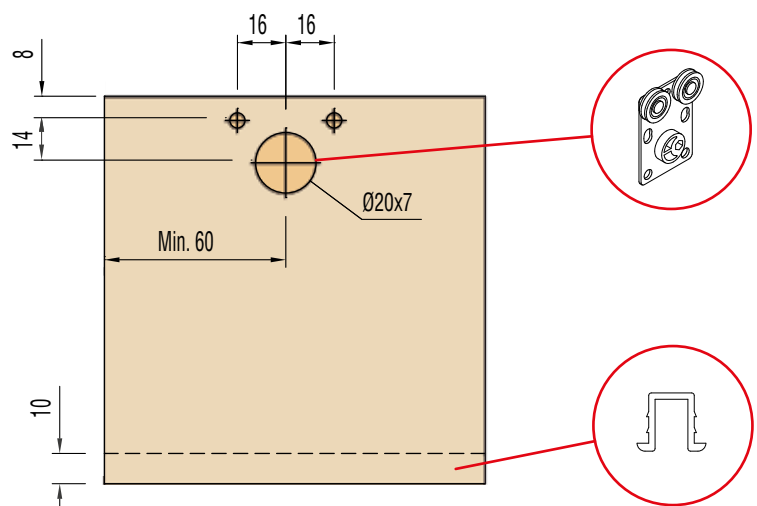



Sistemi scorrevoli per mobili / Sliding systems for furniture

Sezione verticale / Vertical section

Anta esterna / Outer door

KIT 0203R AC - MAX 15 KG

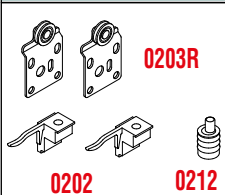

KIT 0204R AC - MAX 25 KG

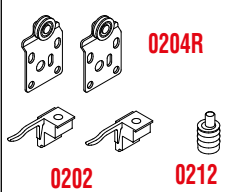

KIT 0205R AC - MAX 25 KG

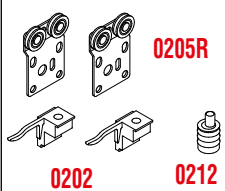

KIT 0206R AC - MAX 40 KG

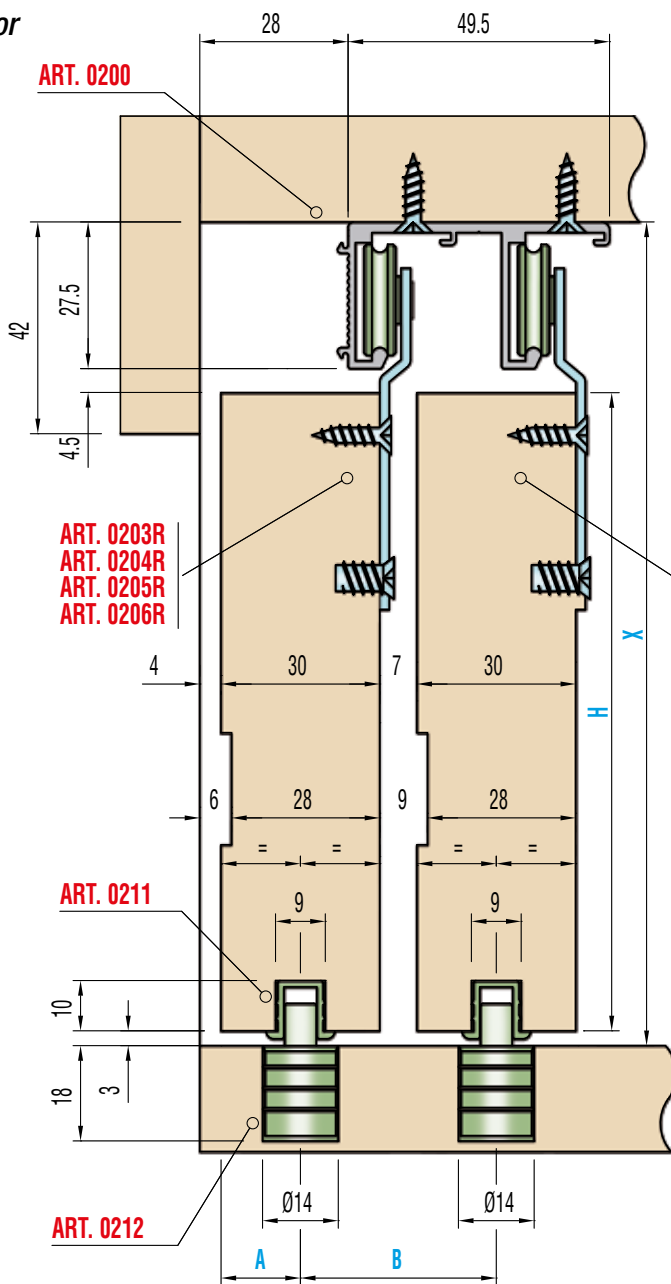
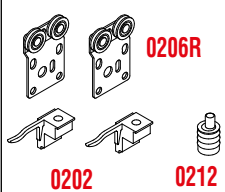

Anta interna / Inner door

KIT 0203P AC - MAX 15 KG

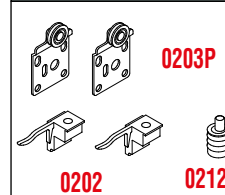

KIT 0204P AC - MAX 25 KG

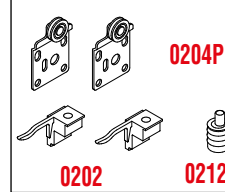

KIT 0205P AC - MAX 25 KG

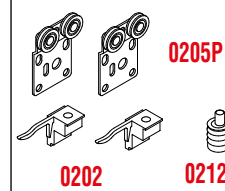

KIT 0206P AC - MAX 40 KG

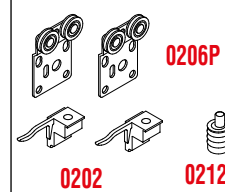

H =	X - 35
A =	34 - S*/2
B =	37

S* (spessore / thickness)
min.28 - max 30

Legenda KIT / Kit Legend

0202	Fermo superiore dx - sx Right hand - left hand upper stopper
0203P	Carrello con piega con 1 rullo senza eccentrico Truck with groove with 1 roller without eccentric
0204P	Carrello con piega con 1 cuscinetto senza eccentrico Truck with groove with 1 ball bearing without eccentric
0205P	Carrello con piega con 2 rulli senza eccentrico Truck with groove with 2 rollers without eccentric
0206P	Carrello con piega con 2 cuscinetti senza eccentrico Truck with groove with 2 ball bearings without eccentric
0203R	Carrello con piega con 1 rullo senza eccentrico Truck with groove with 1 roller without eccentric
0204R	Carrello con piega con 1 cuscinetto senza eccentrico Truck with groove with 1 ball bearing without eccentric
0205R	Carrello con piega con 2 rulli senza eccentrico Truck with groove with 2 rollers without eccentric
0206R	Carrello con piega con 2 cuscinetti senza eccentrico Truck with groove with 2 ball bearings without eccentric
0212	Guida inferiore eccentrica Lower eccentric runner

Schema Foratura ante / Doors drilling

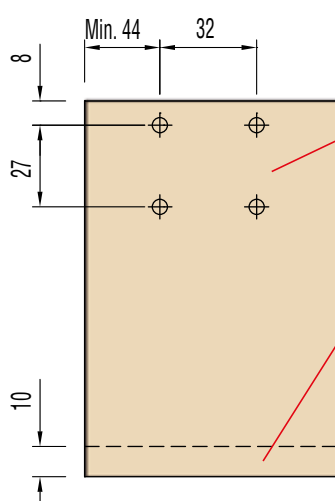

Legenda altri componenti Legend other items

0200		Profilo alluminio superiore Upper aluminium profile
0211		Profilo plastica inferiore Lower plastic profile

Sezione verticale / Vertical section

Anta esterna / Outer door

KIT 0207R AC - MAX 15 KG		0207R
		0202 0212
KIT 0208R AC - MAX 25 KG		0208R
		0202 0212
KIT 0209R AC - MAX 25 KG		0209R
		0202 0212
KIT 0210R AC - MAX 40 KG		0210R
		0202 0212

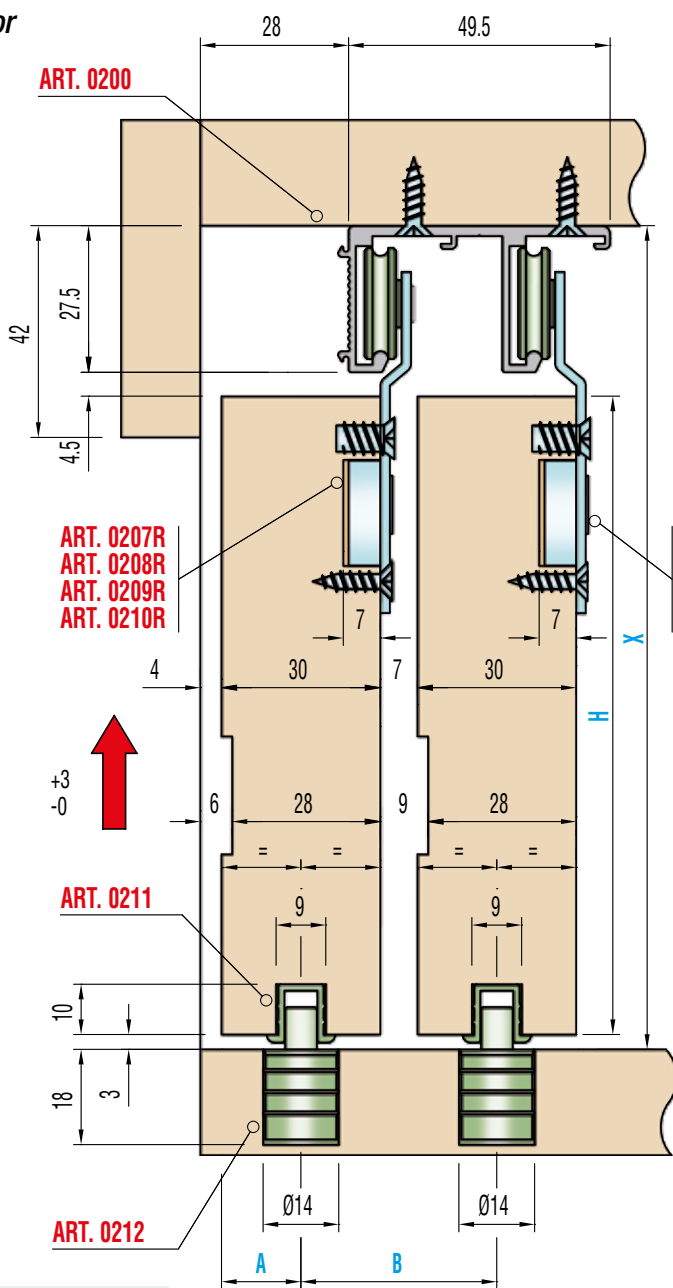

Anta interna / Inner door

KIT 0207P AC - MAX 15 KG		0207P
		0202 0212
KIT 0208P AC - MAX 25 KG		0208P
		0202 0212
KIT 0209P AC - MAX 25 KG		0209P
		0202 0212
KIT 0210P AC - MAX 40 KG		0210P
		0202 0212

H	$X - 35$
A	$34 - S^*/2$
B	37

S* (spessore / thickness)
min.28 - max 30

Legenda KIT / Kit Legend

0202	Fermo superiore dx - sx Right hand - left hand upper stopper
0207R	Carrello con piega con 1 rullo con eccentrico Truck with groove with 1 roller with eccentric
0208R	Carrello con piega con 1 cuscinetto con eccentrico Truck with groove with 1 ball bearing with eccentric
0209R	Carrello con piega con 2 rulli con eccentrico Truck with groove with 2 rollers with eccentric
0210R	Carrello con piega con 2 cuscinetti con eccentrico Truck with groove with 2 ball bearings with eccentric
0207P	Carrello con piega con 1 rullo con eccentrico Truck with groove with 1 roller with eccentric
0208P	Carrello con piega con 1 cuscinetto con eccentrico Truck with groove with 1 ball bearing with eccentric
0209P	Carrello con piega con 2 rulli con eccentrico Truck with groove with 2 rollers with eccentric
0210P	Carrello con piega con 2 cuscinetti con eccentrico Truck with groove with 2 ball bearings with eccentric
0212	Guida inferiore eccentrica Lower eccentric runner

Schema Foratura ante / Doors drilling

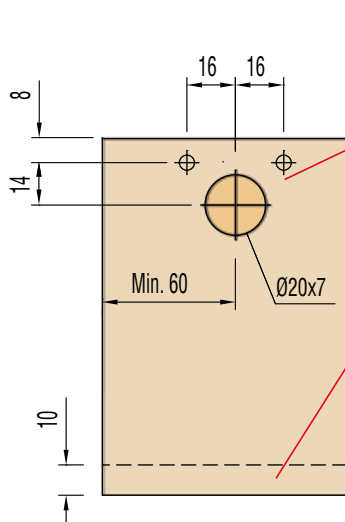

Legenda altri componenti Legend other items

0200		Profilo alluminio superiore Upper aluminium profile
0211		Profilo plastica inferiore Lower plastic profile



Sistemi scorrevoli per mobili / Sliding systems for furniture

Sezione verticale / Vertical section

Anta esterna / Outer door

KIT 0203 AC - MAX 15 KG
0203
0202 0212
KIT 0204 AC - MAX 25 KG
0204
0202 0212
KIT 0205 AC - MAX 25 KG
0205
0202 0212
KIT 0206 AC - MAX 40 KG
0206
0202 0212

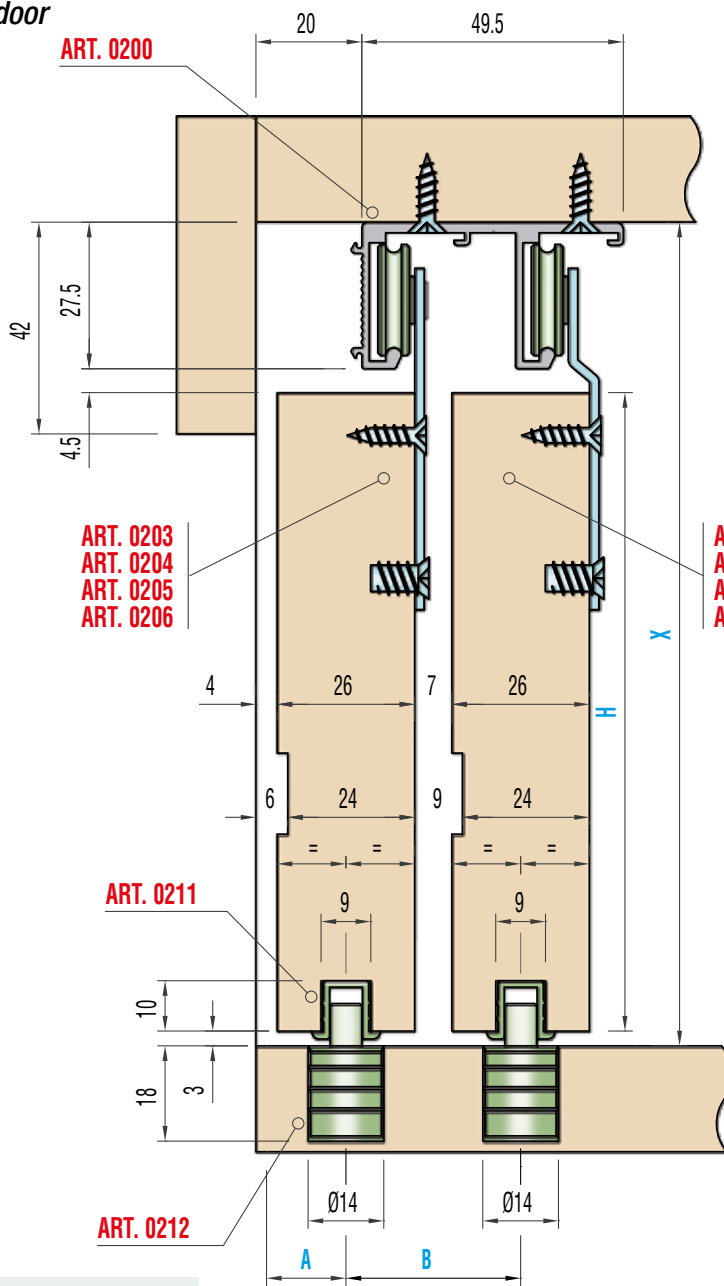

Anta interna / Inner door

KIT 0203P AC - MAX 15 KG
0203P
0202 0212
KIT 0204P AC - MAX 25 KG
0204P
0202 0212
KIT 0205P AC - MAX 25 KG
0205P
0202 0212
KIT 0206P AC - MAX 40 KG
0206P
0202 0212

H =	X - 35
A =	30 - S*/2
B =	33

S* (spessore / thickness) min.24 - max 26

Legenda KIT / Kit Legend

0202	Fermo superiore dx - sx <i>Right hand - left hand upper stopper</i>
0203	Carrello con 1 rullo senza eccentrico <i>Truck with 1 roller without eccentric</i>
0204	Carrello con 1 cuscinetto senza eccentrico <i>Truck with 1 ball bearing without eccentric</i>
0205	Carrello con 2 rulli senza eccentrico <i>Truck with 2 rollers without eccentric</i>
0206	Carrello con 2 cuscinetti senza eccentrico <i>Truck with 2 ball bearings without eccentric</i>
0203P	Carrello con piega con 1 rullo senza eccentrico <i>Truck with groove with 1 roller without eccentric</i>
0204P	Carrello con piega con 1 cuscinetto senza eccentrico <i>Truck with groove with 1 ball bearing without eccentric</i>
0205P	Carrello con piega con 2 rulli senza eccentrico <i>Truck with groove with 2 rollers without eccentric</i>
0206P	Carrello con piega con 2 cuscinetti senza eccentrico <i>Truck with groove with 2 ball bearings without eccentric</i>
0212	Guida inferiore eccentrica <i>Lower eccentric runner</i>

Schema Foratura ante / Doors drilling

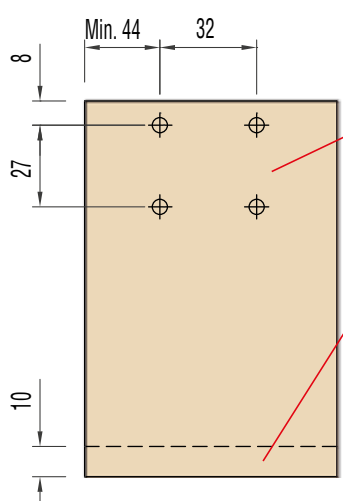

Legenda altri componenti / Legend other items

0200		Profilo alluminio superiore <i>Upper aluminium profile</i>
0211		Profilo plastica inferiore <i>Lower plastic profile</i>

Sezione verticale / Vertical section

Anta esterna / Outer door

KIT 0207 AC - MAX 15 KG
0207
0202
0212
KIT 0208 AC - MAX 25 KG
0208
0202
0212
KIT 0209 AC - MAX 25 KG
0209
0202
0212
KIT 0210 AC - MAX 40 KG
0210
0202
0212

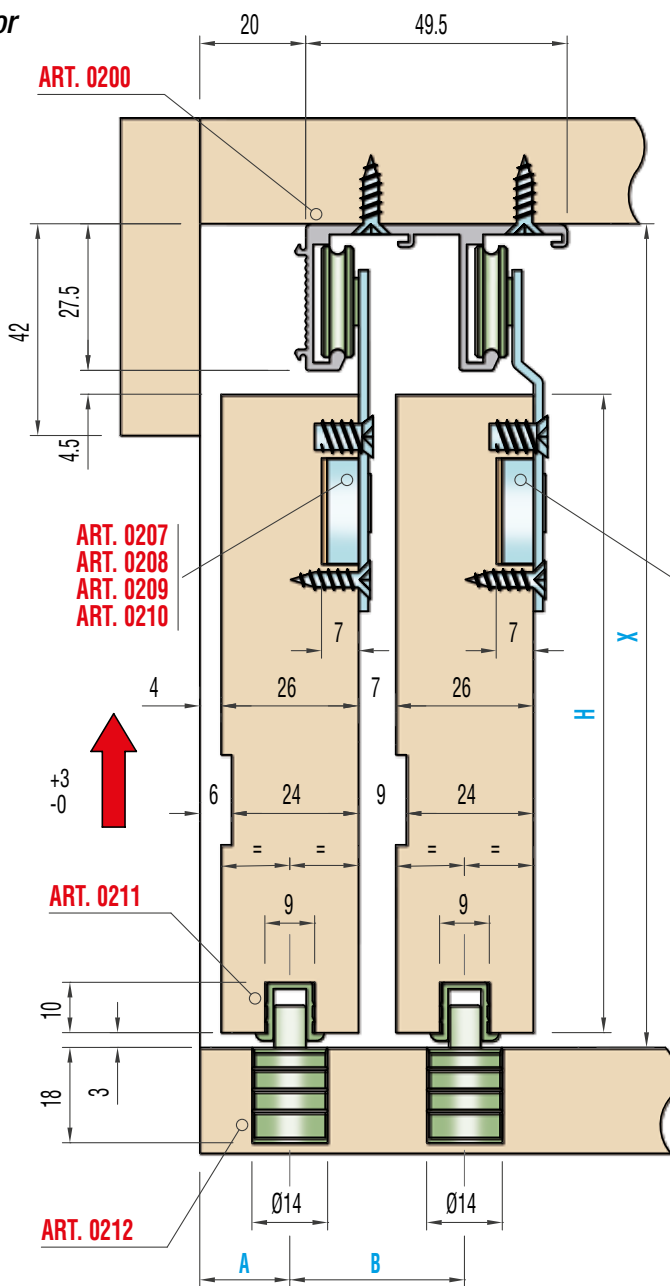

Anta interna / Inner door

KIT 0207P AC - MAX 15 KG
0207P
0202
0212
KIT 0208P AC - MAX 25 KG
0208P
0202
0212
KIT 0209P AC - MAX 25 KG
0209P
0202
0212
KIT 0210P AC - MAX 40 KG
0210P
0202
0212

H	= X - 35
A	= 30 - S*/2
B	= 33

S* (spessore / thickness) min.24 - max 26

Legenda KIT / Kit Legend

0202	Fermo superiore dx - sx Right hand - left hand upper stopper
0207	Carrello con 1 rullo con eccentrico Truck with 1 roller with eccentric
0208	Carrello con 1 cuscinetto con eccentrico Truck with 1 ball bearing with eccentric
0209	Carrello con 2 rulli con eccentrico Truck with 2 rollers with eccentric
0210	Carrello con 2 cuscinetti con eccentrico Truck with 2 ball bearings with eccentric
0207P	Carrello con piega con 1 rullo con eccentrico Truck with groove with 1 roller with eccentric
0208P	Carrello con piega con 1 cuscinetto con eccentrico Truck with groove with 1 ball bearing with eccentric
0209P	Carrello con piega con 2 rulli con eccentrico Truck with groove with 2 rollers with eccentric
0210P	Carrello con piega con 2 cuscinetti con eccentrico Truck with groove with 2 ball bearings with eccentric
0212	Guida inferiore eccentrica Lower eccentric runner

Schema Foratura ante / Doors drilling

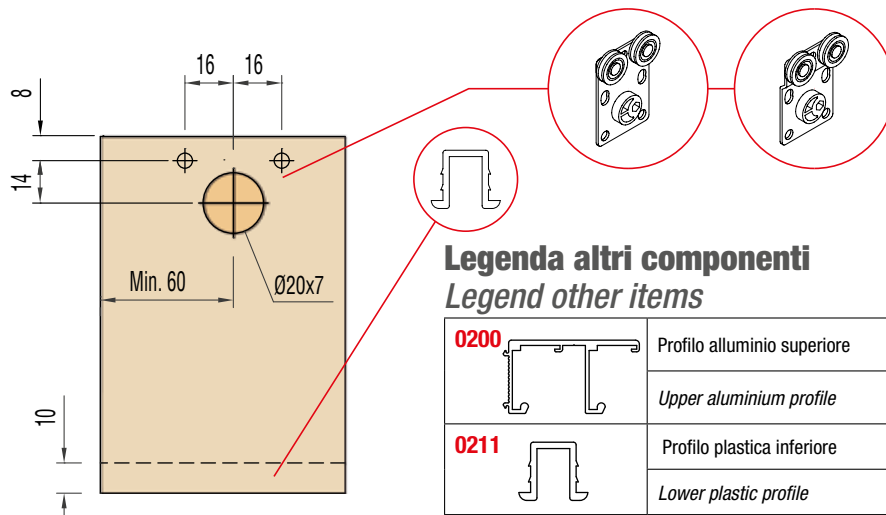

Legenda altri componenti / Legend other items

0200		Profilo alluminio superiore Upper aluminium profile
0211		Profilo plastica inferiore Lower plastic profile



Sezione verticale / Vertical section

Anta esterna / Outer door

KIT 0207P AC - MAX 15 KG
0207P
0202 0212
KIT 0208P AC - MAX 25 KG
0208P
0202 0212
KIT 0209P AC - MAX 25 KG
0209P
0202 0212
KIT 0210P AC - MAX 40 KG
0210P
0202 0212

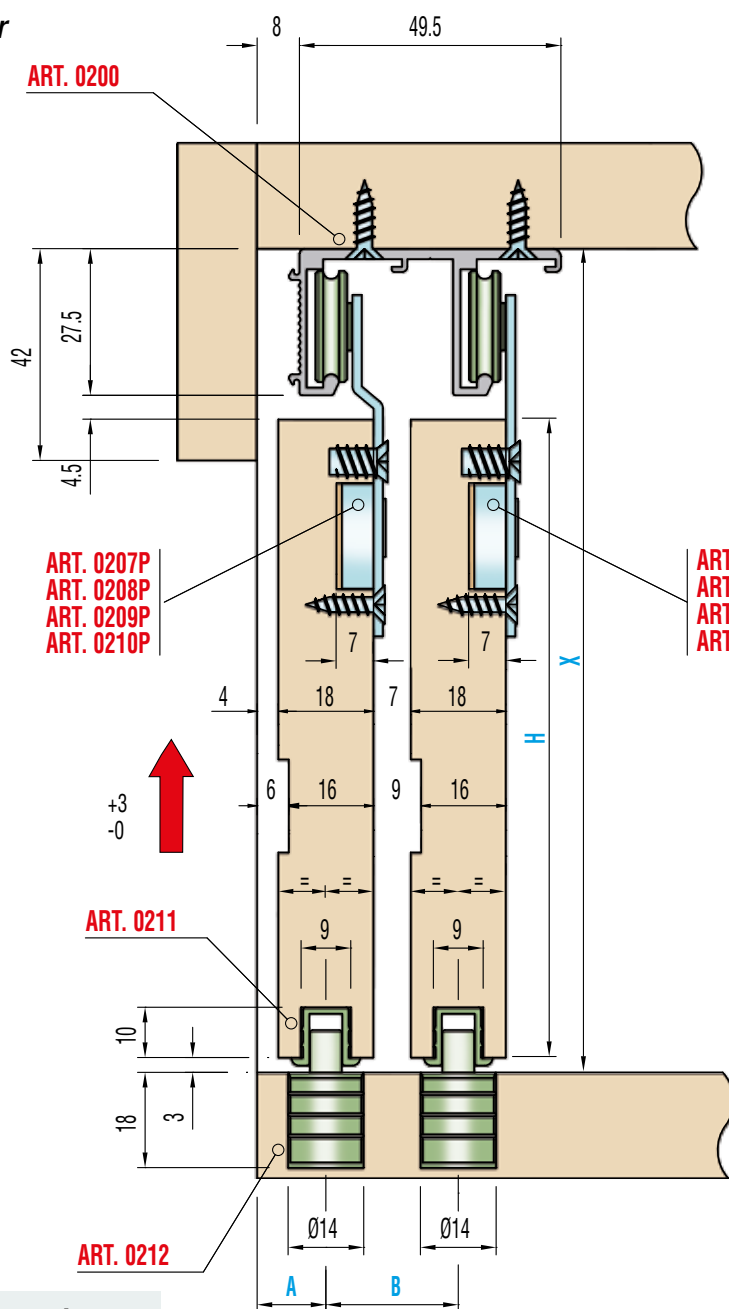

Anta interna / Inner door

KIT 0207 AC - MAX 15 KG
0207
0202 0212
KIT 0208 AC - MAX 25 KG
0208
0202 0212
KIT 0209 AC - MAX 25 KG
0209
0202 0212
KIT 0210 AC - MAX 40 KG
0210
0202 0212

H	$X - 35$
A	$22 - S^*/2$
B	25

S* (spessore / thickness) min.16 - max 18

Legenda KIT / Kit Legend

0202	Fermo superiore dx - sx Right hand - left hand upper stopper
0207	Carrello con 1 rullo con eccentrico Truck with 1 roller with eccentric
0208	Carrello con 1 cuscinetto con eccentrico Truck with 1 ball bearing with eccentric
0209	Carrello con 2 rulli con eccentrico Truck with 2 rollers with eccentric
0210	Carrello con 2 cuscinetti con eccentrico Truck with 2 ball bearings with eccentric
0207P	Carrello con piega con 1 rullo con eccentrico Truck with groove with 1 roller with eccentric
0208P	Carrello con piega con 1 cuscinetto con eccentrico Truck with groove with 1 ball bearing with eccentric
0209P	Carrello con piega con 2 rulli con eccentrico Truck with groove with 2 rollers with eccentric
0210P	Carrello con piega con 2 cuscinetti con eccentrico Truck with groove with 2 ball bearings with eccentric
0212	Guida inferiore eccentrica Lower eccentric runner

Schema Foratura ante / Doors drilling

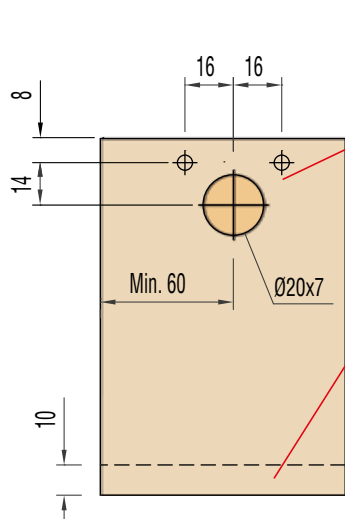

Legenda altri componenti Legend other items

0200		Profilo alluminio superiore Upper aluminium profile
0211		Profilo plastica inferiore Lower plastic profile



Sistemi scorrevoli per mobili / Sliding systems for furniture

Sezione verticale / Vertical section

Anta esterna / Outer door

KIT 0203P AC - MAX 15 KG

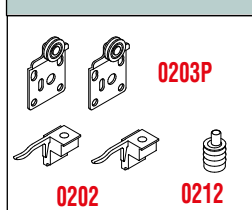

KIT 0204P AC - MAX 25 KG

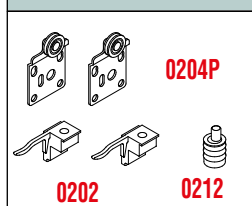

KIT 0205P AC - MAX 25 KG

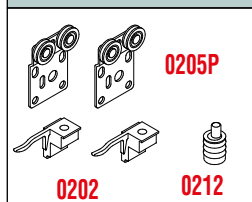

KIT 0206P AC - MAX 40 KG

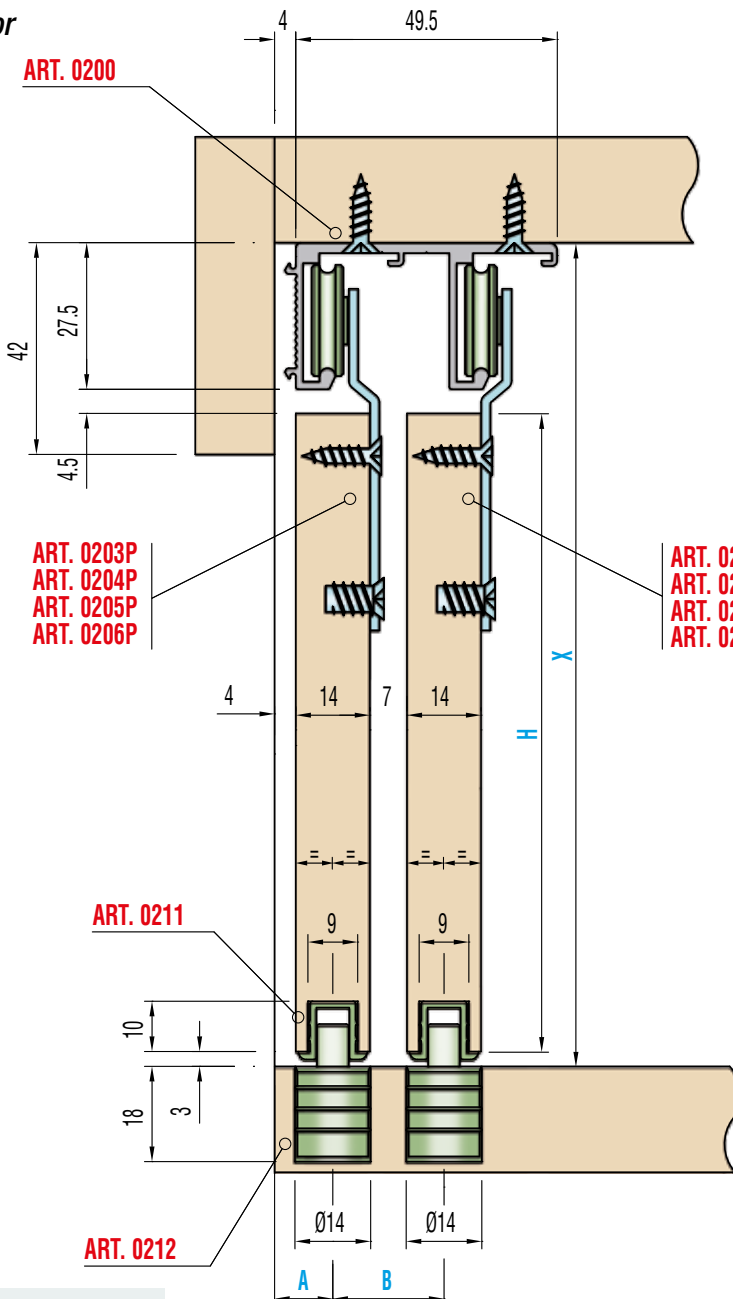
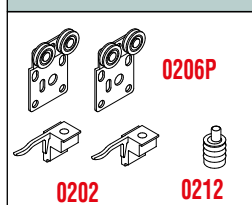

Anta interna / Inner door

KIT 0203R AC - MAX 15 KG

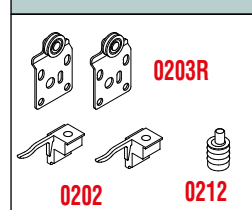

KIT 0204R AC - MAX 25 KG

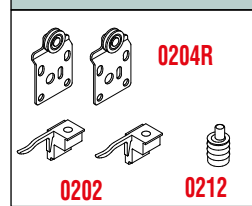

KIT 0205R AC - MAX 25 KG

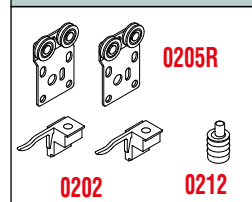

KIT 0206R AC - MAX 40 KG

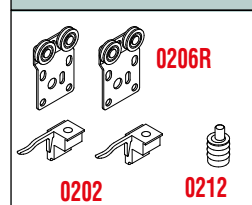

H	X - 35
A	11
B	21

S* (spessore / thickness)
min.14 - max 30

Legenda KIT / Kit Legend

0202	Fermo superiore dx - sx Right hand - left hand upper stopper
0203P	Carrello con piega con 1 rullo senza eccentrico Truck with groove with 1 roller without eccentric
0204P	Carrello con piega con 1 cuscinetto senza eccentrico Truck with groove with 1 ball bearing without eccentric
0205P	Carrello con piega con 2 rulli senza eccentrico Truck with groove with 2 rollers without eccentric
0206P	Carrello con piega con 2 cuscinetti senza eccentrico Truck with groove with 2 ball bearings without eccentric
0203R	Carrello con piega con 1 rullo senza eccentrico Truck with groove with 1 roller without eccentric
0204R	Carrello con piega con 1 cuscinetto senza eccentrico Truck with groove with 1 ball bearing without eccentric
0205R	Carrello con piega con 2 rulli senza eccentrico Truck with groove with 2 rollers without eccentric
0206R	Carrello con piega con 2 cuscinetti senza eccentrico Truck with groove with 2 ball bearings without eccentric
0212	Guida inferiore eccentrica Lower eccentric runner

Schema Foratura ante / Doors drilling

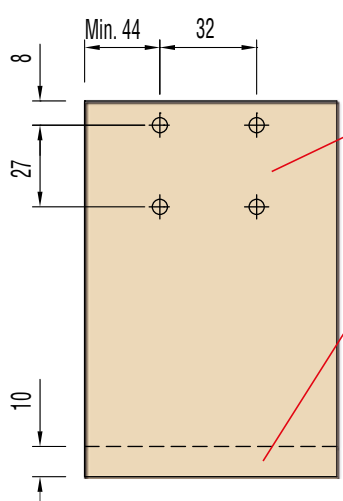

Legenda altri componenti Legend other items

0200		Profilo alluminio superiore Upper aluminium profile
0211		Profilo plastica inferiore Lower plastic profile

Sezione verticale / Vertical section

Anta esterna / Outer door

KIT 0207P AC - MAX 15 KG

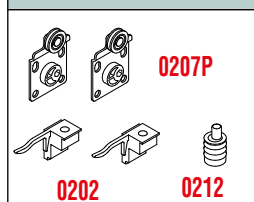

KIT 0208P AC - MAX 25 KG

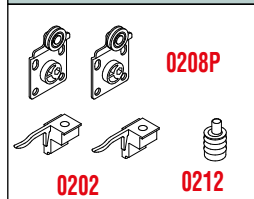

KIT 0209P AC - MAX 25 KG

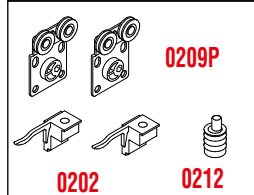

KIT 0210P AC - MAX 40 KG

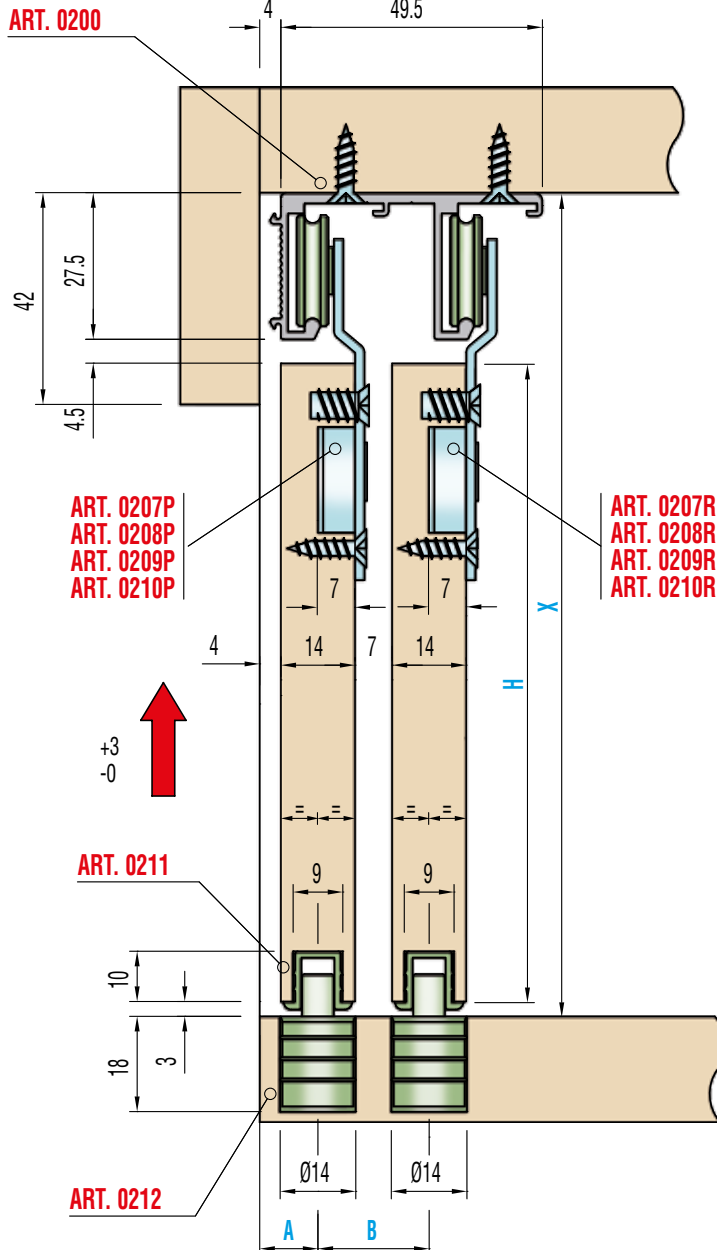
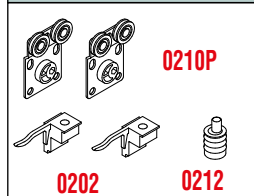

Anta interna / Inner door

KIT 0207R AC - MAX 15 KG

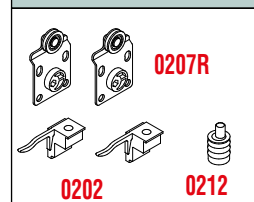

KIT 0208R AC - MAX 25 KG

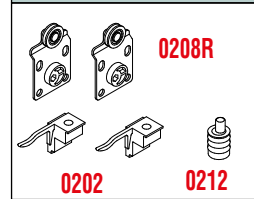

KIT 0209R AC - MAX 25 KG

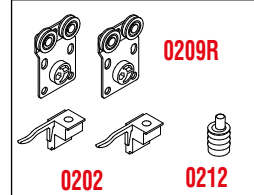

KIT 0210R AC - MAX 40 KG

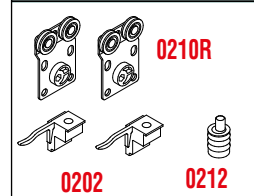

H	X - 35
A	11
B	21

S* (spessore / thickness) min.14 - max 30

Legenda KIT / Kit Legend

0202	Fermo superiore dx - sx Right hand - left hand upper stopper
0207P	Carrello con piega con 1 rullo con eccentrico Truck with groove with 1 roller with eccentric
0208P	Carrello con piega con 1 cuscinetto con eccentrico Truck with groove with 1 ball bearing with eccentric
0209P	Carrello con piega con 2 rulli con eccentrico Truck with groove with 2 rollers with eccentric
0210P	Carrello con piega con 2 cuscinetti con eccentrico Truck with groove with 2 ball bearings with eccentric
0207R	Carrello con piega con 1 rullo con eccentrico Truck with groove with 1 roller with eccentric
0208R	Carrello con piega con 1 cuscinetto con eccentrico Truck with groove with 1 ball bearing with eccentric
0209R	Carrello con piega con 2 rulli con eccentrico Truck with groove with 2 rollers with eccentric
0210R	Carrello con piega con 2 cuscinetti con eccentrico Truck with groove with 2 ball bearings with eccentric
0212	Guida inferiore eccentrica Lower eccentric runner

Schema Foratura ante / Doors drilling

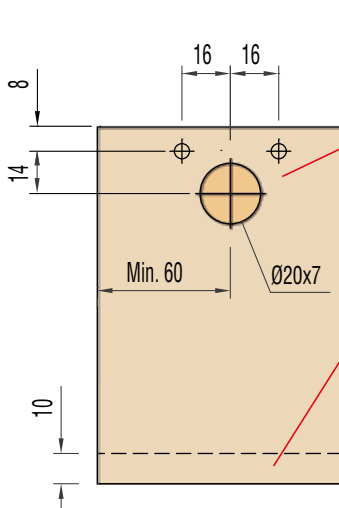

Legenda altri componenti / Legend other items

0200		Profilo alluminio superiore Upper aluminium profile
0211		Profilo plastica inferiore Lower plastic profile



Schema di montaggio / Assembling

1

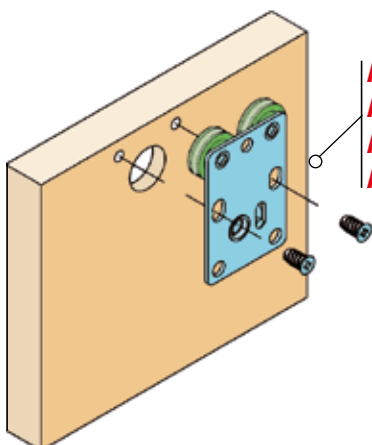

Art. 0207
Art. 0208
Art. 0209
Art. 0210

Montaggio ed uso dei carrelli regolabili Fitting and use of the adjustable trucks

0207	Carrello con 1 rullo con eccentrico Truck with 1 roller with eccentric
0208	Carrello con 1 cuscinetto con eccentrico Truck with 1 ball bearing with eccentric
0209	Carrello con 2 rulli con eccentrico Truck with 2 rollers with eccentric
0210	Carrello con 2 cuscinetti con eccentrico Truck with 2 ball bearings with eccentric

Montare sull'anta i carrelli regolabili avvitando regolarla ruotando l'eccentrico con una chiave esagonale da 6 mm (1).

Fit the door to the furniture piece. If necessary, adjust it by turning the eccentric by means of a 6 mm. hexagonal wrench (1).

Montare l'anta sul mobile e, se necessario, le viti nei fori asolati superiori senza stringerle (2).

Fit adjustable trucks to the door and turn the screws in the upper slots without tightening (2).

Then tighten the screws previously inserted into the upper slots and lock the truck by tightening the screws in the lower slots (3).

2

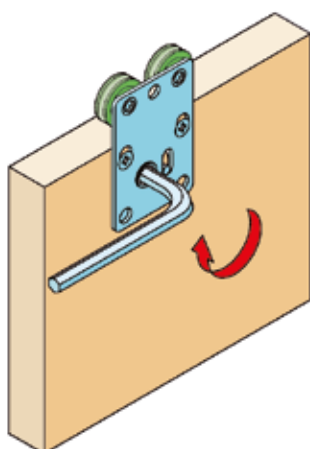

Nota: Lo schema di montaggio è valido anche per i carrelli con piega dotati di eccentrico.
Note: The Assembling instruction can be used for trucks with groove with eccentric too.

3

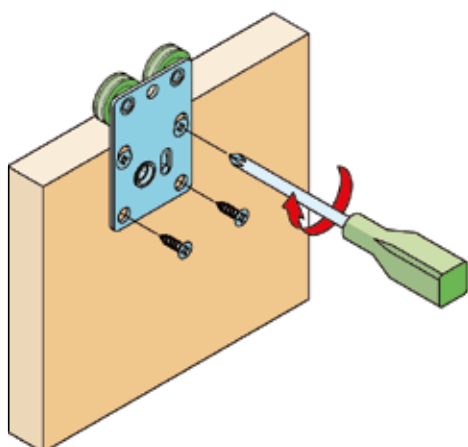

ART. 0201: Supporto / Clip

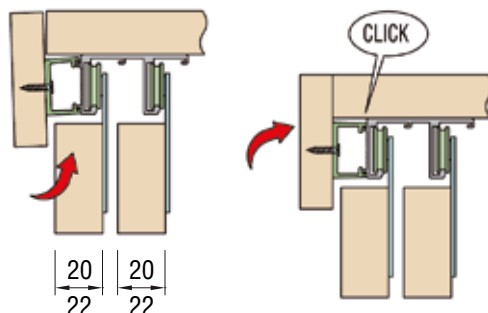

Può essere usato solo su armadi con ante di spessore 20-22 mm. / Can be fitted to wardrobes with 20-22 mm. doors thickness.

Montaggio Ante / Fittings of doors

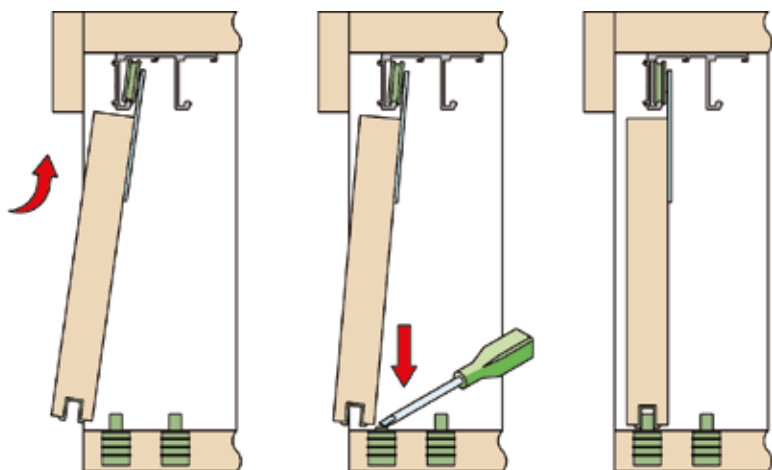

Regolazione / Adjustment

